

HORIZONTAL, VERTICAL OR UPRIGHT OUR DRAG TUBE CONVEYOR SYSTEMS ARE EXTREMELY VERSATILE & FLEXIBLE



DRAG TUBE CONVEYING SYSTEMS



Solutions for the Pharmaceutical, Food, Paint, and Chemical Sectors.



ProChem tube chain conveyers are so flexible that they can be employed in a nearly infinite number of variations. Due to their compact dimensions, low maintenance, ease of use, and astonishingly low energy consumption, the ProChem chain conveyers have rightfully become extremely popular. Our systems are individually customised in a modular design. Layout, materials, and speed will be perfectly adapted to your bulk material. Our tube chain conveyor is available along with many practical components like brush or knocking units for cleaning the chains and for discharging, and special flap or slider systems for intermediate discharge with as little dead space as possible.

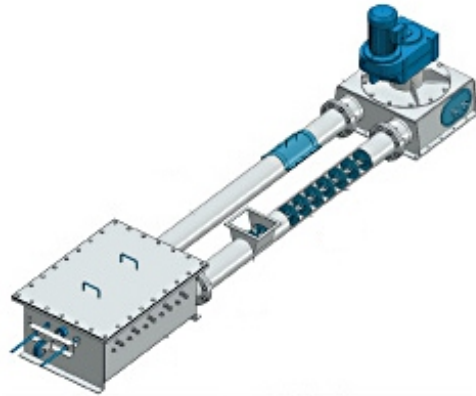
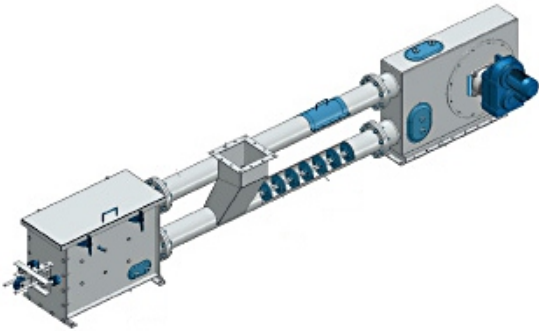

Features:

- Dust-free Operations: Convey product in a completely sealed system.
- Low-horsepower, electric motor drives material for hundreds of feet using minimal energy.
- Move challenging materials.
- One conveyor does the work of several, no problem.
- Modular design allows for optimum conveying, including length, conveyor path, number of inlets or discharge outlets.
- Get longer life from chain than steel cable.
- Work day-in, day-out with minimal chain wear hence increasing productivity
- Discharge 100% of your product.
- Requires minimal maintenance.
- Eliminate multiple conveyors with multiple inlets/outlets.
- GMP compliant design, high quality surface finishes, no dead spaces.

Options



**Self-Cleaning
Discharge Gate**

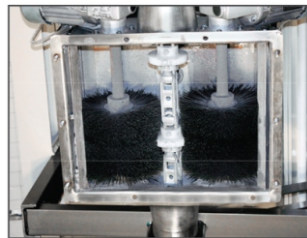

Brush Box

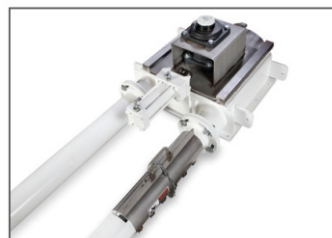

Auto Tensioner



**Flight and Chain
Configurations**